

IMPORTANT PARTS-SERVICE COMMUNICATION

TO: All Service and Parts Managers

DATE: April 12, 2002

NO: CAG-432

SUBJECT: New Direct Spark Igniters for PGA, PGB and PGD Gas/Electric Package Units

Amana has received field reports indicating that the new PGA*C*2E/F, PGB and PGD*C*2E model gas/electric package units may not light properly after having been converted to Propane Gas. This issue affects units built at the end of February 2001 through the end of May 2002 (Serial date codes 0102 through 0205). These units were built using the same burner bracket as used on our current 40" 90% furnaces. This change to the new burner bracket commonized the burner components and reduced the number of service parts required in the field. To address this issue Amana has released a new direct spark igniter (Amana Part # 20261708).

Should you receive a field report or complaint of an ignition problem after the unit has been converted to Propane Gas, check the following items first:

1. Gas pressure - adjust to proper value.
2. Burner positioning - burners should be in locating slots, level front to rear and left to right.
3. Carry over (lighter tube or cross lighter) obstructed - clean.
4. Main burner orifice(s) deformed, or out of alignment to burner - replace.

If after all the above mentioned items (1-4) have been checked and the unit is still not lighting on Propane Gas, the next thing to do would be to replace the direct spark igniter (Amana Part # 20261706 or 07) with the new direct spark igniter (Amana Part # 20261708). This new direct spark igniter places the spark in the main burner stream of burner #1 whereas the previous igniters placed the spark at the crossover between the first and second burner (refer to the figure below).

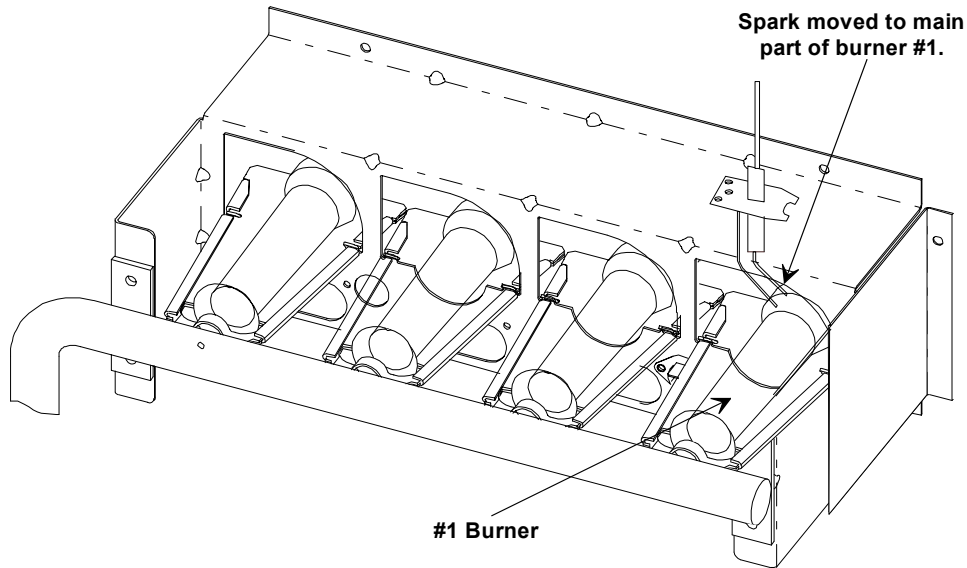

**Location of new Direct Spark Igniter
Amana Part # 20261708**

PGA, PGB and PGD*C*2E/F gas/electric package units manufactured beginning later part of May 2002 (Serial date code 0205 and later) will incorporate the new direct spark igniter (Amana Part # 20261708).

Installed Units

Amana will pay class "A" in-home service rate to install a **new direct spark igniter (Amana Part # 20261708)** on Amana Gas/Electric Package Units (specific models listed above) built between February 2001 and May 2002 (Serial date codes 0102 through 0205) which experience lighting issues when converted to Propane Gas and it was determined that the problem was caused by the direct spark igniter.

FILING PROCEDURES:

A warranty tag (A173 or RF000007) must be completed for each unit serviced. Send the original white copy (Amana copy) plus copy 1 and 2 (Distributor copies) of the tag to the distributor. The distributor will summarize the warranty tags on a PRF (Part Return Form). The Distributor will attach the original white (Amana) copy of the tag and copy 1 (Distributor copy) of the warranty tag to the original white (Amana) copy of the PRF and send to Warranty Administration at Amana, Fayetteville.

Upon receipt of the proper documentation at Amana, Fayetteville, part credit will be issued to the distributor and labor credit directly to the servicer. In the event the dealer is not set up as an authorized servicer, labor will be issued to the distributor (at the distributors rate) to pass along to the dealer.

All claims for credit under this program must be submitted to Warranty Administration at Amana, Fayetteville for processing within the warranty period.